

## 600L PACKAGED PUMP STATION

## SEWAGE

IDEAL FOR DOMESTIC SEWAGE AND DRAINAGE APPLICATIONS

### PACKAGE INCLUDES

- Heavy Duty Roto-molded 600 L polyethylene tank
- REEFE REG015 grinder pump with automatic control
- Complete with 40mm discharge piping, valves and fittings including brass gate and swing check valve, and barrel union for easy connection and pump removal
- High level alarm with audible and visible alarm functions
- Australian made and assembled ready for installation
- Integrated post for alarm & GPO



REEFE Liquid Level Alarm  
(RLA10)



REEFE Submersible Pump  
(REG015)



Cast Iron Impeller  
Components



Stainless Steel Grinder  
Components

### FEATURES

- 600L Nominal Capacity
- Approved to requirements of Australian Standard AS/NZS1546.1
- Tough UV stabilised rotationally moulded polyethylene vessel
- Proven UV stabilised injection moulded lid (RELN Septic Tank)
- Easy 100mm PVC Sewer Pipe inlet connection via Pipe Gasket Seal
- Variable inlet height to suit fall or volume required (between 450L & 600L). Simply drill to desired height in marked positions
- Flanged base designed for hold-down by backfill
- Unique tie down locations on underside of base suit attachment with reo bar set and additional unique flange penetrations for concrete lock down in higher water table areas
- Specially shaped base designed for
  - maximum strength
  - maximum pump out
- Class B and Class D Ductile Iron Access Covers available
- Dual Pump Systems available

## 600L PACKAGED PUMP STATION REEFE REG015 DETAILS

## SEWAGE

### ELECTRICAL DATA

- Rated Voltage: 240V
- Mains Frequency: 50Hz
- Rated output: 1.5kW
- Current: 9.5A
- Capacitor: 30  $\mu$ F
- Motor Duty: Continuous
- Motor Type: Asynchronous
- Motor protection: Built-in thermal overload
- Ingress protection: IPX8
- Insulation class: B
- Power cable length: 10m H07RNF

### LIQUIDS

- Clean water temperature range: 40 °C

### MATERIALS

- Pump body: Cast Iron
- Motor shroud: 304 Stainless Steel
- Impeller: Cast Iron
- Motor Shaft: Stainless Steel
- Cutting Device: Stainless Steel
- Shaft seal: Dual mechanical seals (Ceramic/Carbon)

### INSTALLATION

- Max. Ambient temperature: 40°C
- Pipe Connection: 2"

### SPECIFICATIONS

Overall height: 1266mm  
Overall diameter: 1250mm  
Weight: 78kg  
Nominal Capacity: 600L

### HYDRAULIC PERFORMANCE CHART

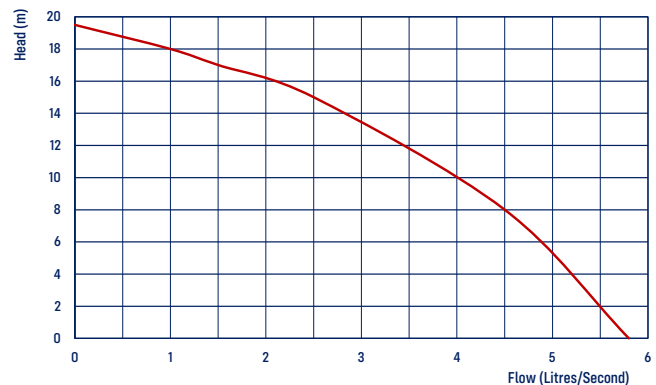

### SITE EXCAVATION DIMENSIONS

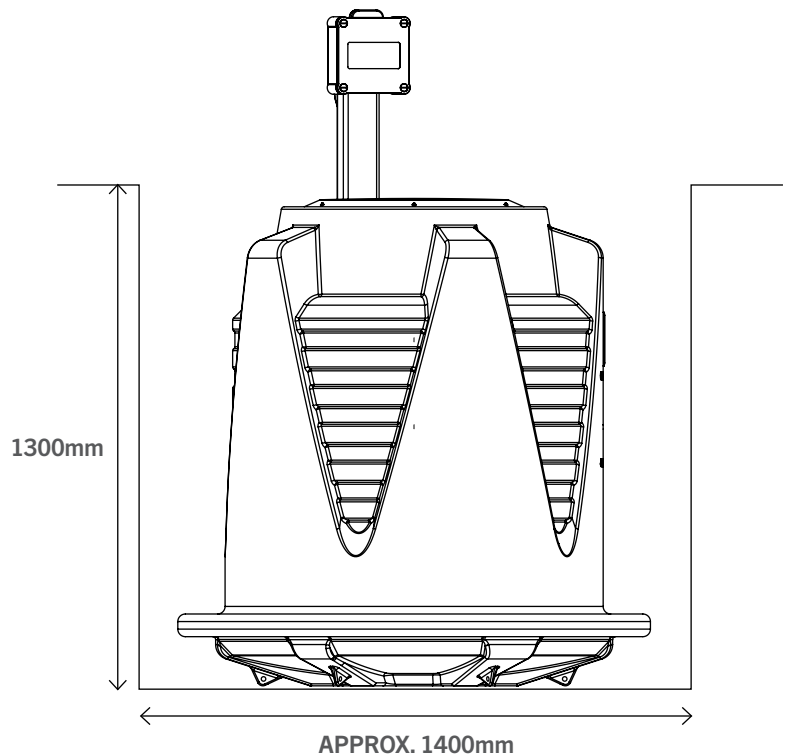

### CONTACT US

Alphatreat Pty Ltd  
ABN 64 143 207 658

9 Mackie Way, Brendale, QLD, 4500  
Phone: 07 3205 3666  
Facsimile: 07 3205 7155  
Hours: 7:30am - 4:00pm (Mon-Fri)  
Email: [info@wastewaterequipment.com.au](mailto:info@wastewaterequipment.com.au)

[wastewaterequipment.com.au](http://wastewaterequipment.com.au)